

### Primary Characteristics

$I_F$	2.0	A
$V_{RRM}$	20~200	V
$I_{FSM}$	50	A
$V_F$	0.55~0.95	V

### Features

- The plastic package carries Underwriters Laboratory Flammability Classification 94V-0
- For surface mounted applications
- Built-in strain relief, ideal for automated placement
- Low reverse leakage
- High forward surge current capability
- High temperature soldering guaranteed 250°C/10 seconds at terminals

### Mechanical Data

- Case : Molded plastic body
- Terminals : Solder plated, solderable per MIL-STD-750, Method 2026
- Polarity : Polarity symbol marking on body
- Mounting Position : Any
- Weight : 0.0014 ounce, 0.038 grams

### Package Outline Dimensions

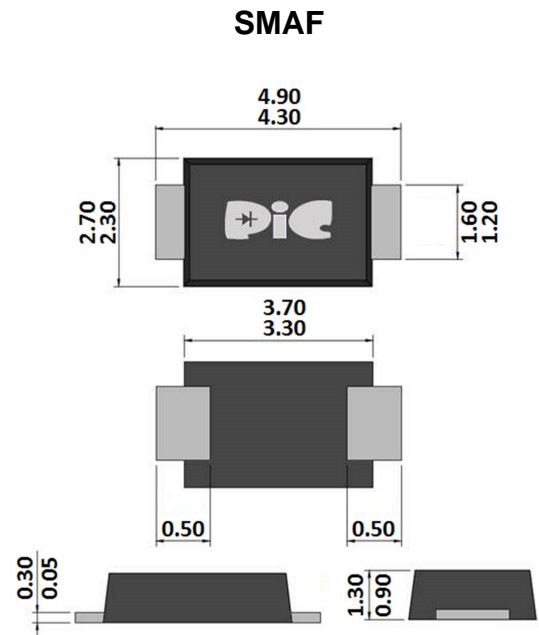

Unit : millimeters

### MAXIMUM RATINGS (TA=25°C unless otherwise noted)

Parameter	SYMBOLS	SS22F	SS24F	SS26F	SS28F	SS210F	SS215F	SS220F	UNITS
Maximum repetitive peak reverse voltage	$V_{RRM}$	20	40	60	80	100	150	200	V
Maximum RMS voltage	$V_{RMS}$	14	28	42	56	70	105	140	V
Maximum DC blocking voltage	$V_{DC}$	20	40	60	80	100	150	200	V
Maximum average forward rectified current at $T_L=100^\circ\text{C}$	$I_{(AV)}$	2.0							A
Peak forward surge current, 8.3ms single half sine-wave superimposed on rated load	$I_{FSM}$	50.0							A
Maximum instantaneous forward voltage at 2.0A	$V_F$	0.55	0.70	0.85		0.95		V	
Maximum DC reverse current $T_A=25^\circ\text{C}$ at rated DC blocking voltage $T_A=125^\circ\text{C}$	$I_R$	0.5 50		0.05 10			mA		
Typical thermal resistance	$R_{qJA}$	70.0							°C/W
Operating junction temperature range	$T_J$	-55 to +125			-55 to +150			°C	
Storage temperature range	$T_{STG}$	-55 to +150							°C

### Rating and Characteristics Curves

FIG. 1- DERATING CURVE OUTPUT RECTIFIED CURRENT

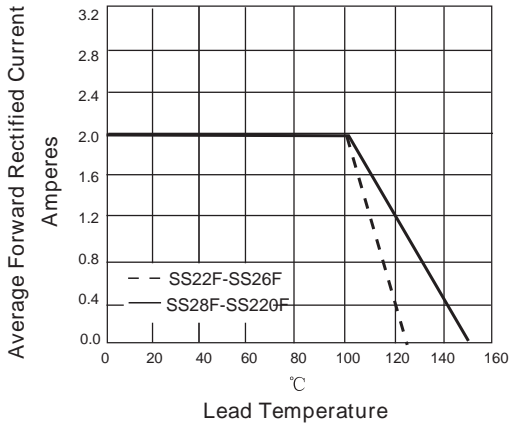

FIG. 2-MAXIMUM NON-REPETITIVE PEAK FORWARD SURGE CURRENT PER LEG

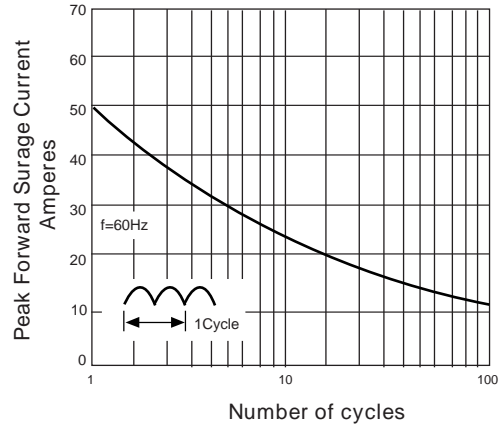

FIG. 3-TYPICAL FORWARD VOLTAGE CHARACTERISTICS

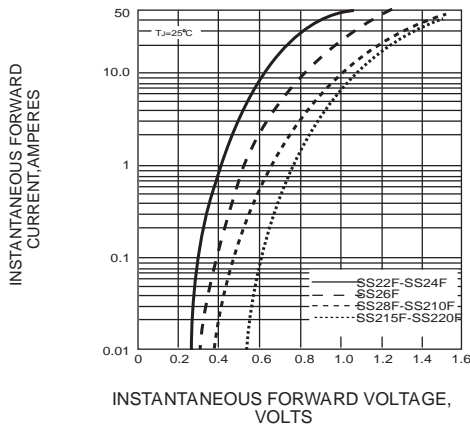
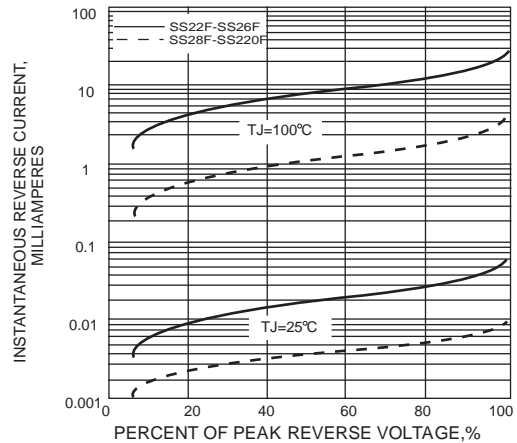
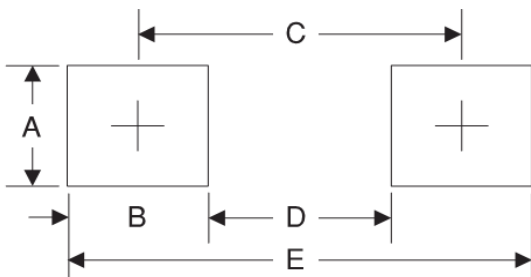

FIG. 4-TYPICAL REVERSE LEAKAGE CHARACTERISTICS



### Suggested Pad Layout



Symbol	Unit (mm)	Unit (inch)
A	1.68	0.066
B	1.52	0.060
C	3.90	0.154
D	2.00	0.078
E	5.10	0.200

### Packaging Specifications

Package	W (mm)	A (mm)	B (mm)	C (mm)	d1 (mm)	d (mm)	E (mm)	F (mm)	P (mm)	P0 (mm)	P1 (mm)	T (mm)
SOD-123FL	8±0.2	2.00±0.1	3.85±0.1	1.1±0.1	1.0	1.50±0.1	1.75±0.1	3.5±0.05	4±0.1	4±0.05	2±0.05	0.23±0.05
SOD-123HE	8±0.3	2.00±0.1	4.00±0.1	1.45±0.1	1.0	1.55±0.1	1.75±0.1	3.5±0.05	4±0.1	4±0.10	2±0.05	0.23±0.10
SMAF	12±0.3	2.9±0.1	5.5±0.1	2.1±0.1	1.5	1.55±0.1	1.75±0.1	5.5±0.05	4±0.1	4±0.10	2±0.05	0.23±0.10
SMA-S	12±0.2	2.65±0.1	5.25±0.1	1.35±0.1	1.0	1.55±0.1	1.75±0.1	5.5±0.05	4±0.1	4±0.05	2±0.05	0.23±0.10
SMA-HE	12±0.2	2.65±0.1	5.25±0.1	1.35±0.1	1.0	1.55±0.1	1.75±0.1	5.5±0.05	4±0.1	4±0.05	2±0.05	0.23±0.10

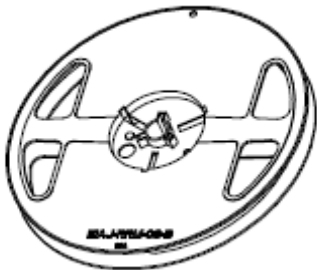
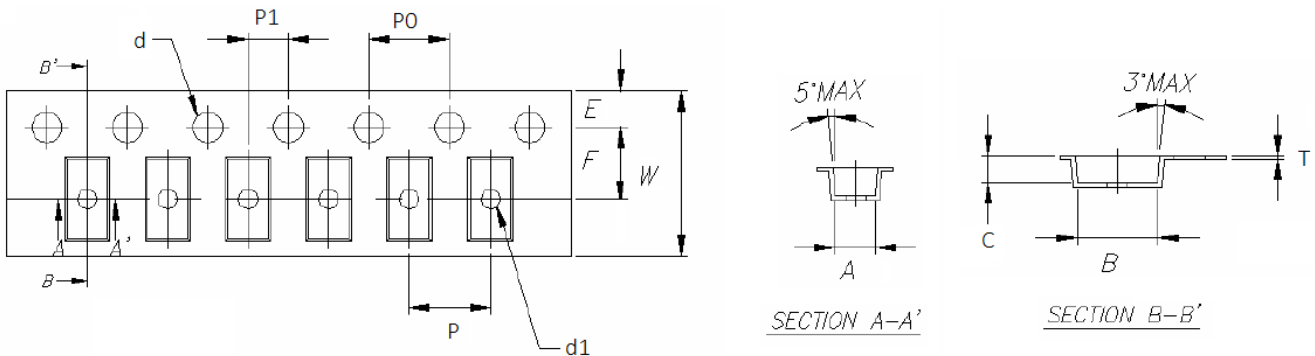

Package	D (max.) (mm)	D1 (min.) (mm)	D2 (mm)	G (min.) (mm)	W1 (min.) (mm)
SOD-123FL	178	50.0	13.0±0.2	8.4	11.4
SOD-123HE	178	50.0	13.0±0.2	8.4	11.4
SMAF	178	50.0	13.0±0.2	12.4	18.0
	330	50.0	13.0±0.2	12.4	18.0
SMA-S	178	50.0	13.0±0.2	12.4	18.0
SMA-HE	178	50.0	13.0±0.2	12.4	18.0

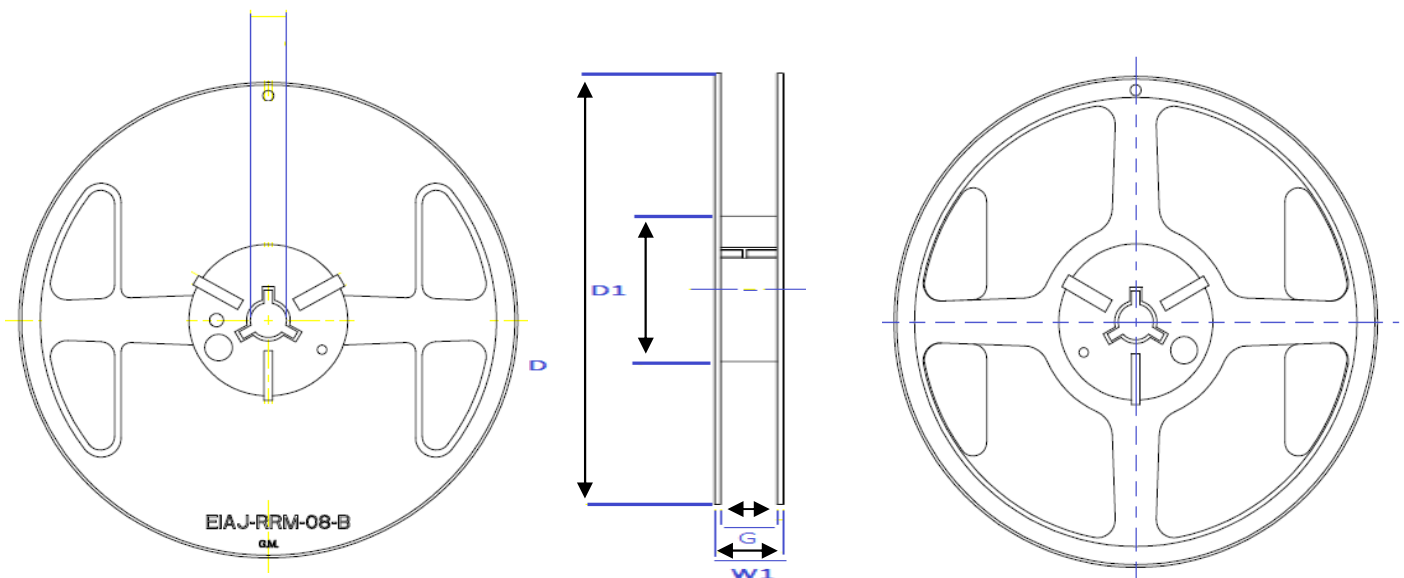

### Recommend IR Reflow Soldering Thermal Profile

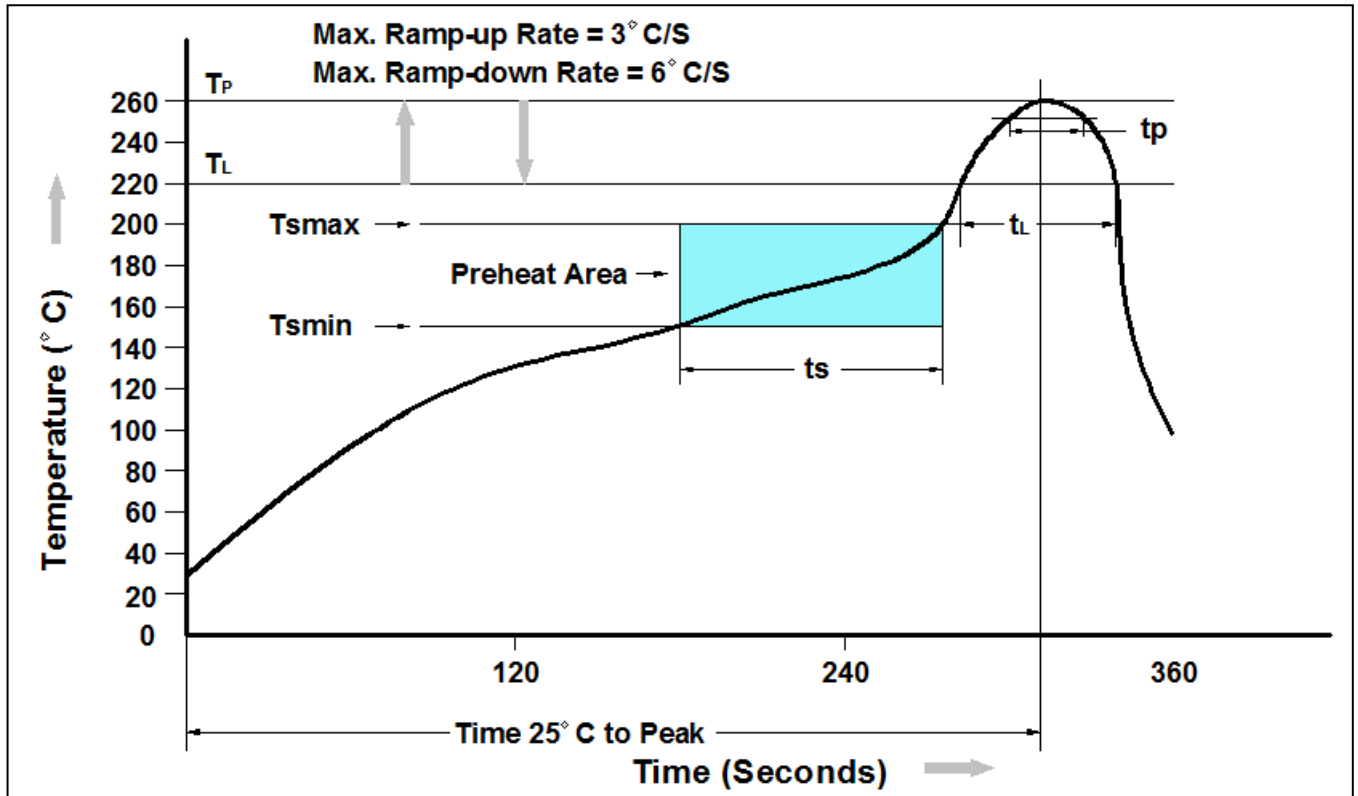

Profile Feature	Pb-Free Assembly Profile
Temperature Min. (T <sub>smin</sub> )	150°C
Temperature Max. (T <sub>smax</sub> )	200°C
Time (t <sub>s</sub> ) from (T <sub>smin</sub> to T <sub>smax</sub> )	60-120 seconds
Average Ramp-up Rate (t <sub>L</sub> to t <sub>P</sub> )	3°C/second max.
Liquidous Temperature (T <sub>L</sub> )	217°C
Time (t <sub>L</sub> ) Maintained Above (T <sub>L</sub> )	60 – 150 seconds
Peak Temperature	260°C +0°C / -5°C
Time (t <sub>P</sub> ) within 5°C of actual Peak Temperature	30 seconds
Ramp-down Rate (T <sub>P</sub> to T <sub>L</sub> )	6°C/second max
Time 25°C to Peak Temperature	8 minutes max.

### Ordering Information

Part Number	Description	Quantity
SS22F~SS220F	SMAF Reel	3000 pcs

## **DISCLAIMER**

- The information in this document and any product described herein are subject to change without notice and should not be construed as a commitment by PACELEADER, PACELEADER reserves the right to make changes to the information in this document.
- Though PACELEADER makes effort to improve product quality and reliability, Product can malfunction and fail due to their inherent electrical sensitivity and vulnerability to physical stress, it is the responsibility of the customer, when utilizing PACELEADER products, to comply with the standards of safety in making a safe design for entire system and to avoid situation in which a malfunction or failure occurs. In developing a new design, customer should ensure that the device which is shown in this document is used within specified operating ranges.
- The information contained herein is presented only as a guide for the applications of our products. No responsibility is assumed by PACELEADER for any infringements of patents or other rights of the third parties which may result from its use.